

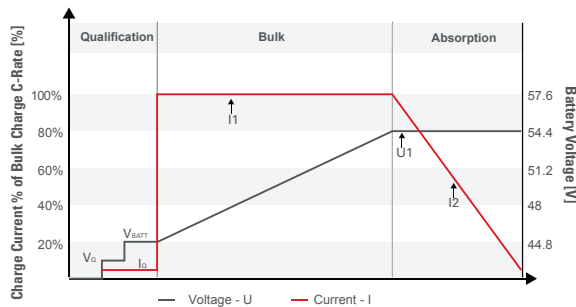

# LiFePO<sub>4</sub> BATTERY

# S48-6650LFP

Rolls LFP batteries allow for equipment design and functionality improvements and deliver productivity gains through enhanced cycling, charge time and weight reductions in stationary and mobile applications. Dramatic improvements in cycle life and charge efficiency combined with zero maintenance requirements provide the end-user with significant cost of ownership savings.



**Efficient and Stable Discharge**  
Deliver > 95% of their capacity at high and stable voltages, increasing equipment performance and reducing motor fatigue.

**Partial State of Charge (SOC)**  
Rolls LFP batteries will not suffer negative effects from partial SOC.

**Battery Management System**  
Integrated Battery Management System to prevent abuse outside of current, voltage and temperature limits.

**Renewable System Ready**  
Xanbus comm port provides plug and play integration with SE Conext XW+, SW, SCP, ComBox and Solar Charge Controllers

Nominal Voltage	48 V
Qualification Voltage (V <sub>Q</sub> *)	Min 12V / Max 48 V (I <sub>Q</sub> < 1 A)
Battery Voltage (V <sub>BATT</sub> )	≥ 40 V
Bulk Current (I <sub>1</sub> )	65 A recommended 130 A maximum
Absorption Voltage (U <sub>1</sub> )	54.4 V
Termination Charge Current	I <sub>2</sub> ≤ 2 A

\*Qualification is optional to utilize Auto-On feature

**CAUTION:**

Do not mix with lead acid batteries when recycling. Do not mix with lead acid batteries when recycling. Do not mix with lead acid batteries when recycling.

## DIMENSIONS

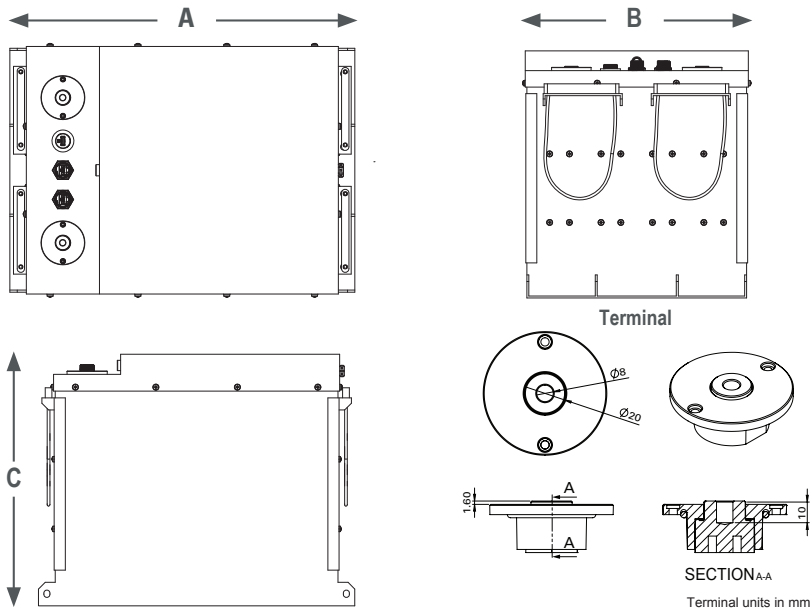

**NOTE:**  
Qualification is a hand shaking procedure that allows a charger to wake up an Auto-On equipped Rolls LFP battery. Qualification is an optional feature and is not required for standard charging.

**CAUTION :**  
Extra considerations must be given to depths of discharge, operating voltages and currents when designing systems for use at maximum operating temperatures.

### SAFETY & PERFORMANCE CERTIFIED

- IEC 62133
- UL 2271
- UL 1973
- UN 38.3

### SHIPPING CLASSIFICATION

- UN 3480, Class 9 (Lithium ion batteries)

## Specifications

Length (A)	471.5 mm	18.5 in
Width (B)	347.5 mm	13.7 in
Height (C)	375 mm	14.7 in
Weight	87 kg	192 lb
Terminal	M8	
Terminal Torque	9 Nm +/- 3	6.64 ft-lb
Case Material	Steel	
IP Rating	IP 55	

## Charge & Electrical Specifications

Nominal Voltage	51.2 V
Charge Voltage	54.4 V
Maximum Voltage*	58.4 V
Minimum Voltage	44.8 V
Nominal Capacity	130 Ah
Nominal Energy	6656 Wh
Max Continuous Current	130 Adc
Peak Current	300 Adc (3 seconds)

Electrical Specifications at 25°C.  
\* Do not exceed maximum voltage at the battery terminals.

Constant Power - Minutes of Discharge			
500 W	1000 W	2000 W	2500 W
799	399	200	133
Constant Current - Minutes of Discharge			
@10A	@25A	@50A	@100A
780	312	156	78

Cell Chemistry	LiFePO <sub>4</sub>	
Cell Modules	16S 26P	
Charge Temperature	0°C / 45°C	32°F / 113°F
Discharge Temperature	-20°C / 50°C	-4°F / 122°F
Storage Temperature	-20°C / 45°C	-4°F / 113°F
Self-Discharge 25°C (77°F)	< 3% per month (battery off)	

CAUTION: Extra considerations must be given to depths of discharge, operating voltages and currents when designing systems for use at maximum operating temperatures.



Do not mix with lead acid batteries when recycling.



**LISTED**

LITHIUM-ION STATIONARY APPLICATION BATTERY  
MH63708

**UN38.3 PASSED**  
**TRANSPORT SAFETY CERTIFIED**