



DEEP CYCLE
SERIES: 5000
MODEL: 8 CS 17P

BATTERY ENGINEERING
WWW.ROLLSBATTERY.COM MADE IN CANADA

BATTERY TYPE: 8 VOLTS

DIMENSIONS:

LENGTH	718 MM	28 1/4 INCHES
WIDTH	210 MM	8 1/4 INCHES
HEIGHT	464 MM	18 1/4 INCHES

WEIGHTS:

WEIGHT DRY	108 KG	238 LBS.
WEIGHT WET	133 KG	294 LBS.

CONTAINER CONSTRUCTION:

CONTAINER: (INNER)	POLYPROPYLENE	TERMINALS:	FLAG WITH STAINLESS STEEL NUTS AND BOLTS
COVER: (INNER)	POLYPROPYLENE - HEAT SEALED TO INNER CONTAINER	HANDLES:	MOLDED
CONTAINER: (OUTER)	HIGH DENSITY POLYETHYLENE		
COVER: (OUTER)	HIGH DENSITY POLYETHYLENE SNAP FIT TO OUTER CONTAINER		

PLATES:

POSITIVE PLATE DIMENSION:

HEIGHT	273 MM	10.750 INCHES
WIDTH	143 MM	5.625 INCHES
THICKNESS	6.73 MM	0.265 INCHES

NEGATIVE PLATE DIMENSION:

HEIGHT	273 MM	10.750 INCHES
WIDTH	143 MM	5.625 INCHES
THICKNESS	4.70 MM	0.185 INCHES

CELLS: 4 **PLATES/CELL:** 17

POSITIVE PLATE ENVELOPED BY VERTICAL SLYVER GLASS MAT

SEPARATOR:
THICKNESS 3 MM 0.105 INCHES

INSULATION:
GLASS MAT 1 MM 0.020 INCHES

CAPACITY:

CRANK AMPS:		
COLD (CCA)	0°F / -17.8°C	1357
MARINE (MCA)	32°F / 0°C	1696

ELECTROLYTE RESERVE:
ABOVE PLATES 95 MM 3.75 INCHES

RESERVE CAPACITY:
RC @ 25A 1083 MINUTES

20 HR RATE: 546 50% DOD

	HOUR RATE	SPECIFIC GRAVITY	CAP / AH	CURRENT / AMPS
CAPACITY @	100 HOUR RATE	1.280 SP. GR.	770	7.70
CAPACITY @	72 HOUR RATE	1.280 SP. GR.	726	10.09
CAPACITY @	50 HOUR RATE	1.280 SP. GR.	672	13.43
CAPACITY @	24 HOUR RATE	1.280 SP. GR.	568	23.7
CAPACITY @	20 HOUR RATE	1.280 SP. GR.	546	27.3
CAPACITY @	15 HOUR RATE	1.280 SP. GR.	508	33.9
CAPACITY @	12 HOUR RATE	1.280 SP. GR.	475	39.6
CAPACITY @	10 HOUR RATE	1.280 SP. GR.	453	45.3
CAPACITY @	8 HOUR RATE	1.280 SP. GR.	426	53.2
CAPACITY @	6 HOUR RATE	1.280 SP. GR.	388	64.6
CAPACITY @	5 HOUR RATE	1.280 SP. GR.	366	73
CAPACITY @	4 HOUR RATE	1.280 SP. GR.	339	85
CAPACITY @	3 HOUR RATE	1.280 SP. GR.	306	102
CAPACITY @	2 HOUR RATE	1.280 SP. GR.	262	131
CAPACITY @	1 HOUR RATE	1.280 SP. GR.	186	186



1 STATION RD SPRINGHILL, NOVA SCOTIA CANADA B0M 1X0 1.800.681.9914

REV.2
 Jan-10
 8 CS 17P



PART NUMBER: 8-CS-17P

WEIGHT WET: 294 LB / 134 KG

WEIGHT DRY: 238 LB / 108 KG

CAPACITY 546 AH 20 HR

VOLTAGE: 8 V

OVERALL DIMENSIONS: 28 1/4" X 8 1/4" X 18 1/4"

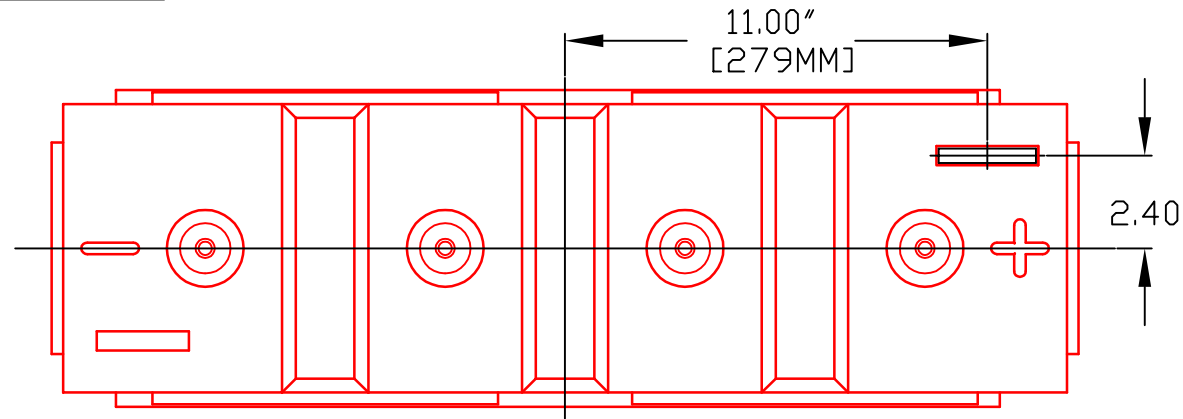

0.70" [18MM]

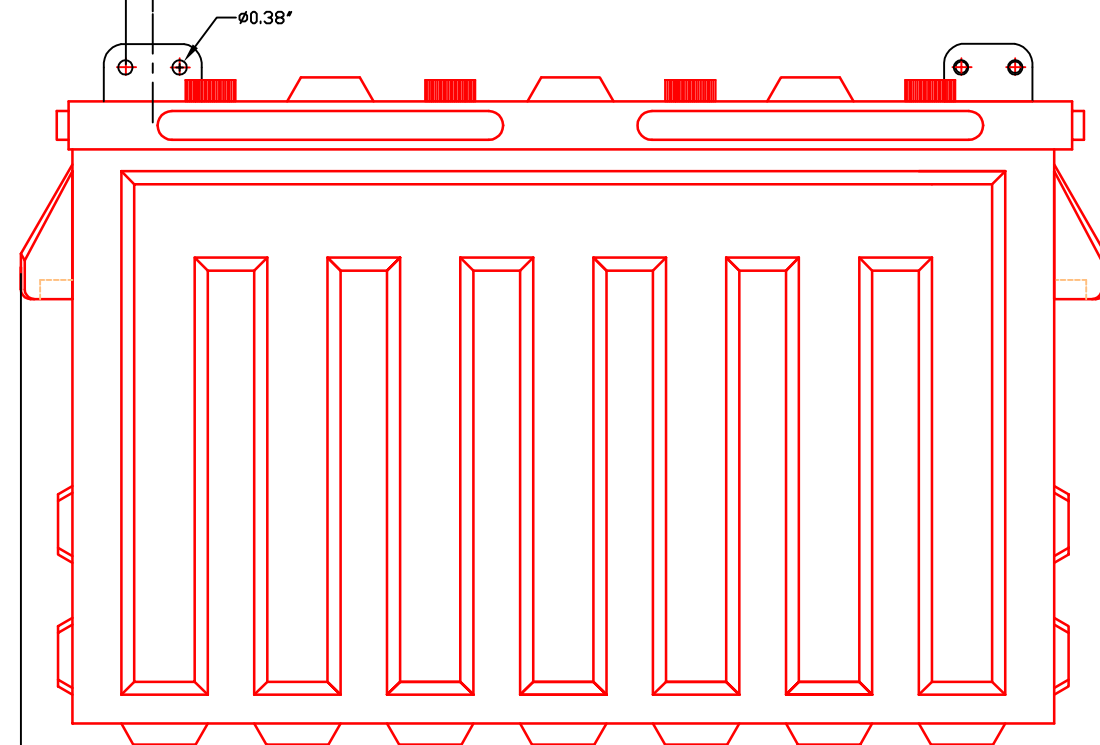

18.25" [464MM]

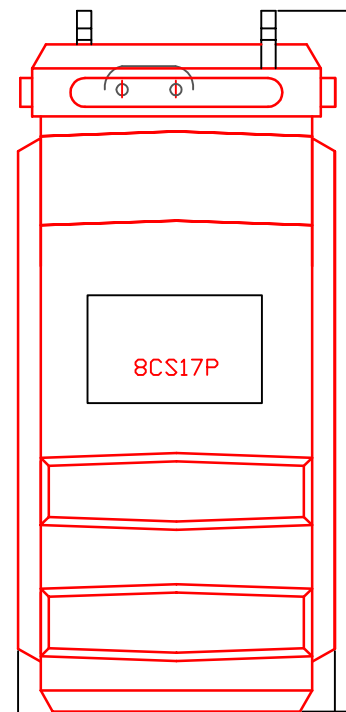

Rolls
BATTERY ENGINEERING

TITLE: 8CS17P

DESCRIPTION:
8V / 4 CELL 17 PLATE (CS) DEEP
CYCLE 5000 SERIES

CONTACT INFO:
WEB: WWW.SURRETTE.COM
E-MAIL: SALES@SURRETTE.COM
PHONE: 1-800-681-9914

SCALE: 1" = 6" 1" = 4" JPEG:
8.5" X 11" 11" X 17" NOT TO SCALE

Drawn by: S. WILES Approved By: D. SURRETTE

DATE: JAN-2010 REVISION 2.0

DRAWING NO.: DWG 036, BD8CS17P