



DEEP CYCLE
SERIES: 5000
MODEL: 8 CH 33 P

BATTERY ENGINEERING
WWW.ROLLSBATTERY.COM MADE IN CANADA

BATTERY TYPE: 8 VOLTS

DIMENSIONS:

LENGTH	718 MM	28 1/4 INCHES
WIDTH	286 MM	11 1/4 INCHES
HEIGHT	464 MM	18 1/4 INCHES

WEIGHTS:

WEIGHT DRY	126 KG	278 LBS.
WEIGHT WET	188 KG	414 LBS.

CONTAINER CONSTRUCTION:

CONTAINER: (INNER)	POLYPROPYLENE	TERMINALS:	FLAG WITH STAINLESS STEEL NUTS AND BOLTS
COVER: (INNER)	POLYPROPYLENE - HEAT SEALED TO INNER CONTAINER	HANDLES:	MOLDED
CONTAINER: (OUTER)	HIGH DENSITY POLYETHYLENE		
COVER: (OUTER)	HIGH DENSITY POLYETHYLENE SNAP FIT TO OUTER CONTAINER		

PLATES:

POSITIVE PLATE DIMENSION:

HEIGHT	270 MM	10.625 INCHES
WIDTH	143 MM	5.625 INCHES
THICKNESS	3.81 MM	0.150 INCHES

CELLS: 4 **PLATES/CELL:** 33

NEGATIVE PLATE DIMENSION:

HEIGHT	270 MM	10.625 INCHES
WIDTH	143 MM	5.625 INCHES
THICKNESS	3.05 MM	0.120 INCHES

SEPARATOR: THICKNESS 3 MM 0.105 INCHES

INSULATION: GLASS MAT 1 MM 0.020 INCHES

CAPACITY:

CRANK AMPS:		
COLD (CCA)	0°F / -17.8°C	2648
MARINE (MCA)	32°F / 0°C	3310

ELECTROLYTE RESERVE: ABOVE PLATES 95 MM 3.75 INCHES

RESERVE CAPACITY: RC @ 25A 1410 MINUTES

20 HR RATE: 890 50% DOD

	20 HOUR RATE	SPECIFIC GRAVITY	CAP / AH	CURRENT / AMPS
CAPACITY @	100 HOUR RATE	1.280 SP. GR.	1255	12.55
CAPACITY @	72 HOUR RATE	1.280 SP. GR.	1184	16.44
CAPACITY @	50 HOUR RATE	1.280 SP. GR.	1095	21.89
CAPACITY @	24 HOUR RATE	1.280 SP. GR.	926	38.6
CAPACITY @	20 HOUR RATE	1.280 SP. GR.	890	44.5
CAPACITY @	15 HOUR RATE	1.280 SP. GR.	828	55.2
CAPACITY @	12 HOUR RATE	1.280 SP. GR.	774	64.5
CAPACITY @	10 HOUR RATE	1.280 SP. GR.	739	73.9
CAPACITY @	8 HOUR RATE	1.280 SP. GR.	694	86.8
CAPACITY @	6 HOUR RATE	1.280 SP. GR.	632	105.3
CAPACITY @	5 HOUR RATE	1.280 SP. GR.	596	119
CAPACITY @	4 HOUR RATE	1.280 SP. GR.	552	138
CAPACITY @	3 HOUR RATE	1.280 SP. GR.	498	166
CAPACITY @	2 HOUR RATE	1.280 SP. GR.	427	214
CAPACITY @	1 HOUR RATE	1.280 SP. GR.	303	303



1 STATION RD SPRINGHILL, NOVA SCOTIA CANADA B0M 1X0 1.800.681.9914

REV.2

Jan-10

8 CH 33 P

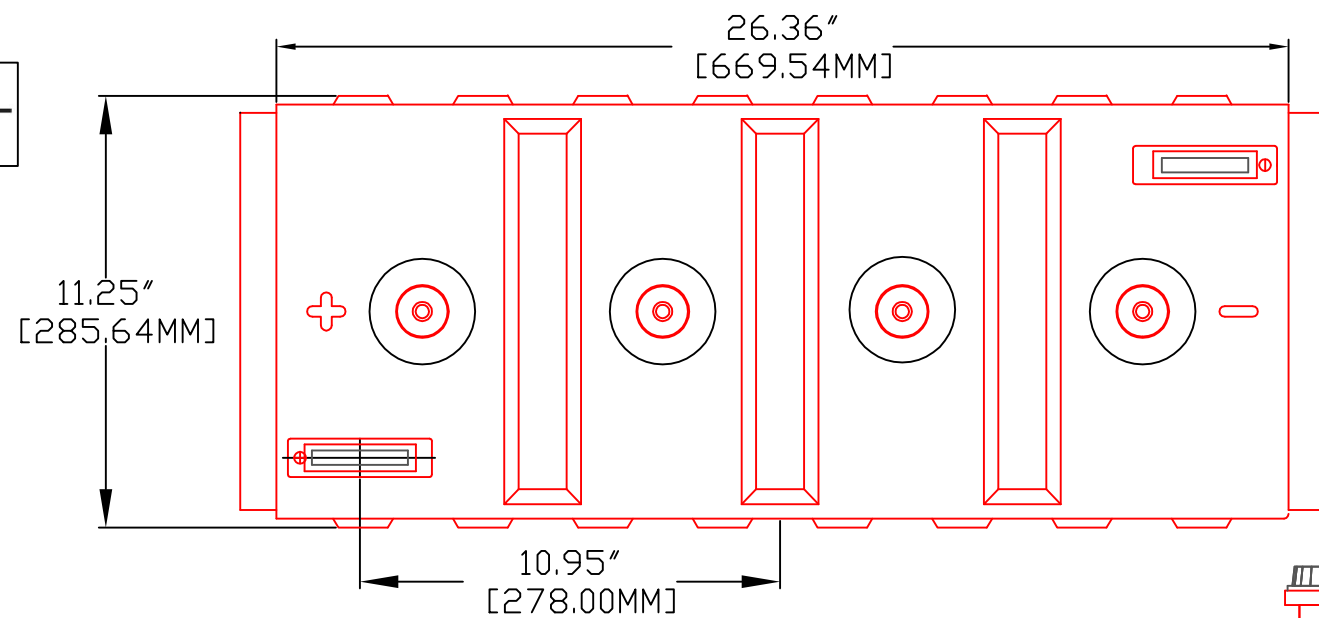

PART NUMBER: 8-CH-33P
 WEIGHT WET: 414 LB / 188 KG
 WEIGHT DRY: 278 LB / 126 KG
 CAPACITY: 890 AH 20 HR
 VOLTAGE: 8 V
 OVERALL DIMENSIONS: 28 1/4" x 11 1/4" x 18 1/4"
 MAX HEIGHT WITH OPTIONAL HYDROCAPS: 18.63" / 473 MM

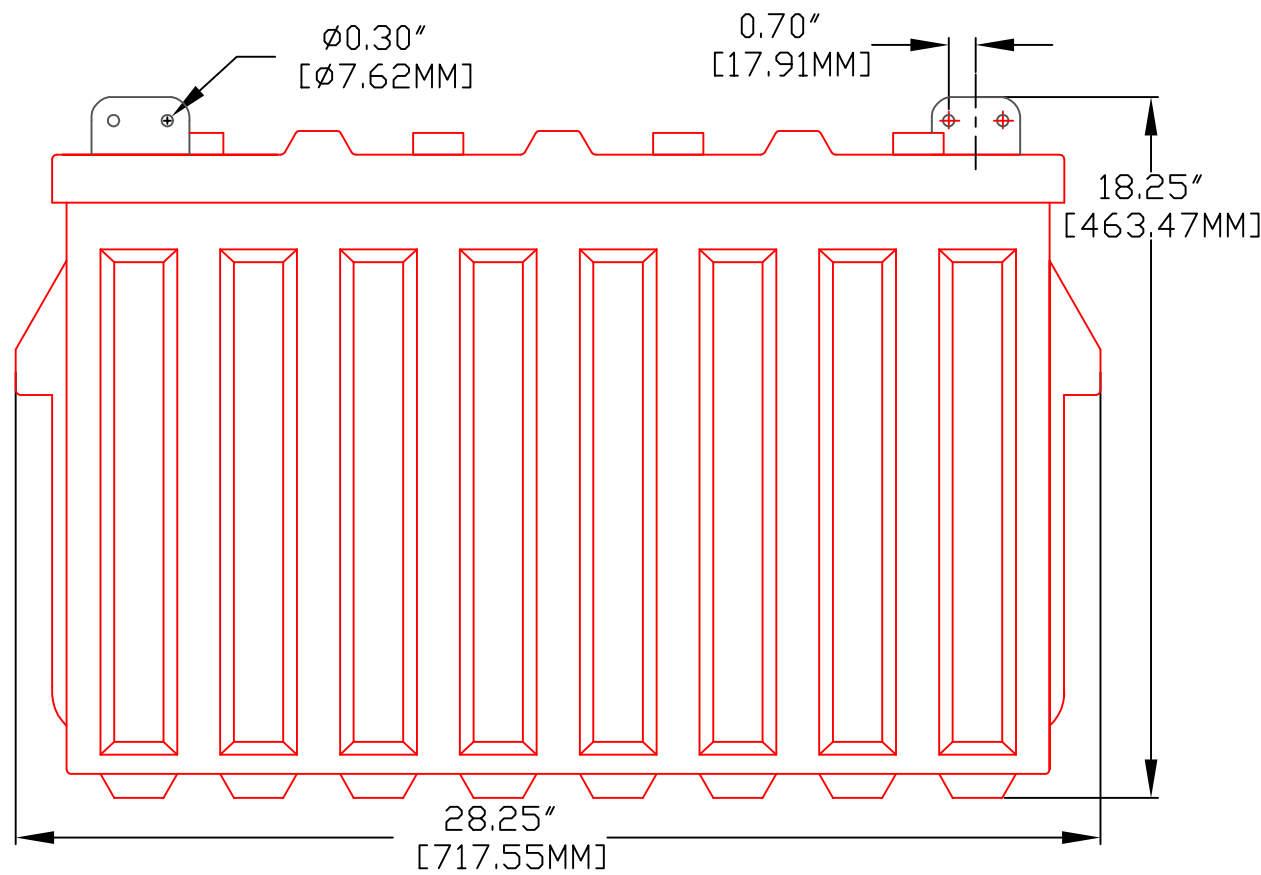
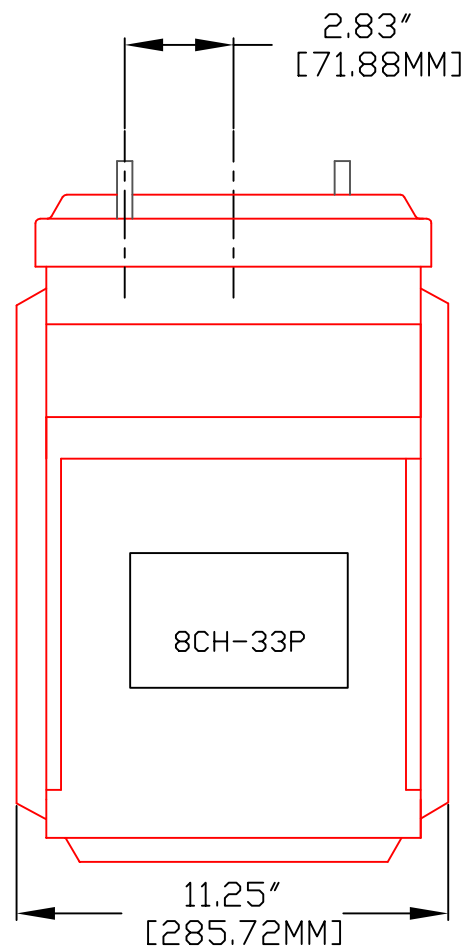

TITLE:	8CH33P
DESCRIPTION:	8V 5000 SERIES
CONTACT INFO:	WEB: WWW.ROLLSBATTERY.COM E-MAIL: SALES@SURRETTE.COM PHONE: 1-800-681-9914
SCALE:	1" = 6" 1" = 4" JPEG: 8.5" X 11" 11" X 17" NOT TO SCALE
Drawn by:	Approved By:
S. WILES	J.D. SURRETTE
DATE:	REVISION:
JAN-2010	2.0
DRAWING NO.:	DWG 016, BD8CH33P