



DEEP CYCLE
SERIES: 5000
MODEL: 2 KS 33P

BATTERY ENGINEERING
WWW.ROLLSBATTERY.COM MADE IN CANADA

BATTERY TYPE: 2 VOLTS

DIMENSIONS:

LENGTH	392 MM	15 7/16 INCHES
WIDTH	211 MM	8 5/16 INCHES
HEIGHT	630 MM	24 13/16 INCHES

WEIGHTS:

WEIGHT DRY	66 KG	145 LBS.
WEIGHT WET	94 KG	208 LBS.

CONTAINER CONSTRUCTION:

CONTAINER: (INNER)	POLYPROPYLENE	TERMINALS:	FLAG WITH STAINLESS STEEL NUTS AND BOLTS
COVER: (INNER)	POLYPROPYLENE - HEAT SEALED TO INNER CONTAINER	HANDLES:	MOLDED
CONTAINER: (OUTER)	HIGH DENSITY POLYETHYLENE		
COVER: (OUTER)	HIGH DENSITY POLYETHYLENE SNAP FIT TO OUTER CONTAINER		

PLATES:

POSITIVE PLATE DIMENSION:

HEIGHT	432 MM	17.000 INCHES
WIDTH	143 MM	5.625 INCHES
THICKNESS	6.99 MM	0.275 INCHES

NEGATIVE PLATE DIMENSION:

HEIGHT	432 MM	17.000 INCHES
WIDTH	143 MM	5.625 INCHES
THICKNESS	4.57 MM	0.180 INCHES

CELLS: 1 **PLATES/CELL:** 33

POSITIVE PLATE DOUBLE WRAPPED WITH SLYVER ENVELOPED WITH HEAVY DUTY SEPARATOR

SEPARATOR:
THICKNESS 3 MM 0.105 INCHES

INSULATION:
GLASS MAT 1 MM 0.020 INCHES

CAPACITY:

CRANK AMPS:		
COLD (CCA)	0°F / -17.8°C	4952
MARINE (MCA)	32°F / 0°C	6190

ELECTROLYTE RESERVE:
ABOVE PLATES 95 MM 3.75 INCHES

RESERVE CAPACITY:
RC @ 25A 4915 MINUTES

20 HR RATE: 1766 50% DOD

	HOUR RATE	SPECIFIC GRAVITY	CAP / AH	CURRENT / AMPS
CAPACITY @	100 HOUR RATE	1.280 SP. GR.	2490	24.90
CAPACITY @	72 HOUR RATE	1.280 SP. GR.	2349	32.62
CAPACITY @	50 HOUR RATE	1.280 SP. GR.	2172	43.44
CAPACITY @	24 HOUR RATE	1.280 SP. GR.	1837	76.5
CAPACITY @	20 HOUR RATE	1.280 SP. GR.	1766	88.3
CAPACITY @	15 HOUR RATE	1.280 SP. GR.	1642	109.5
CAPACITY @	12 HOUR RATE	1.280 SP. GR.	1536	128.0
CAPACITY @	10 HOUR RATE	1.280 SP. GR.	1466	146.6
CAPACITY @	8 HOUR RATE	1.280 SP. GR.	1377	172.2
CAPACITY @	6 HOUR RATE	1.280 SP. GR.	1254	209.0
CAPACITY @	5 HOUR RATE	1.280 SP. GR.	1183	237
CAPACITY @	4 HOUR RATE	1.280 SP. GR.	1095	274
CAPACITY @	3 HOUR RATE	1.280 SP. GR.	989	330
CAPACITY @	2 HOUR RATE	1.280 SP. GR.	848	424
CAPACITY @	1 HOUR RATE	1.280 SP. GR.	600	600



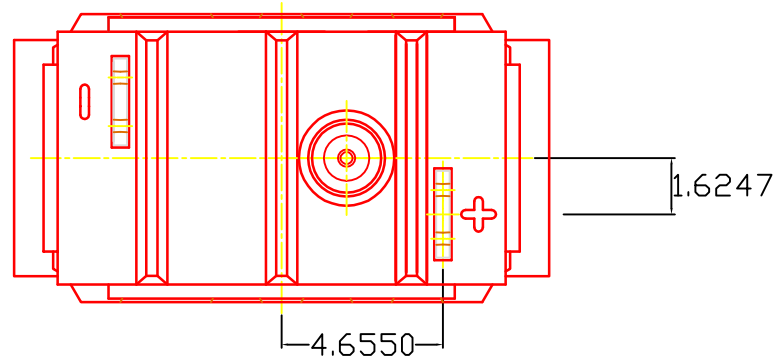

1 STATION RD SPRINGHILL, NOVA SCOTIA CANADA B0M 1X0 1.800.681.9914

REV.2
 Jan-10
 2 KS 33P



PART NUMBER: 2-KS-33P
 WEIGHT WET: 208 LB/ 94 KG
 WEIGHT DRY: 145 LB/ 66 KG
 CAPACITY: 1,766 AH 20 HR
 VOLTAGE: 2 V

OVERALL DIMS: 15 $\frac{7}{16}$ " X 8 $\frac{5}{16}$ " X 24 $\frac{13}{16}$ "

-  MAX HT WITH OPTIONAL HYDROCAPS 25 $\frac{1}{2}$ "
-  MAX HT WITH OPTIONAL LEVEL INDICATOR 26 $\frac{5}{16}$ "

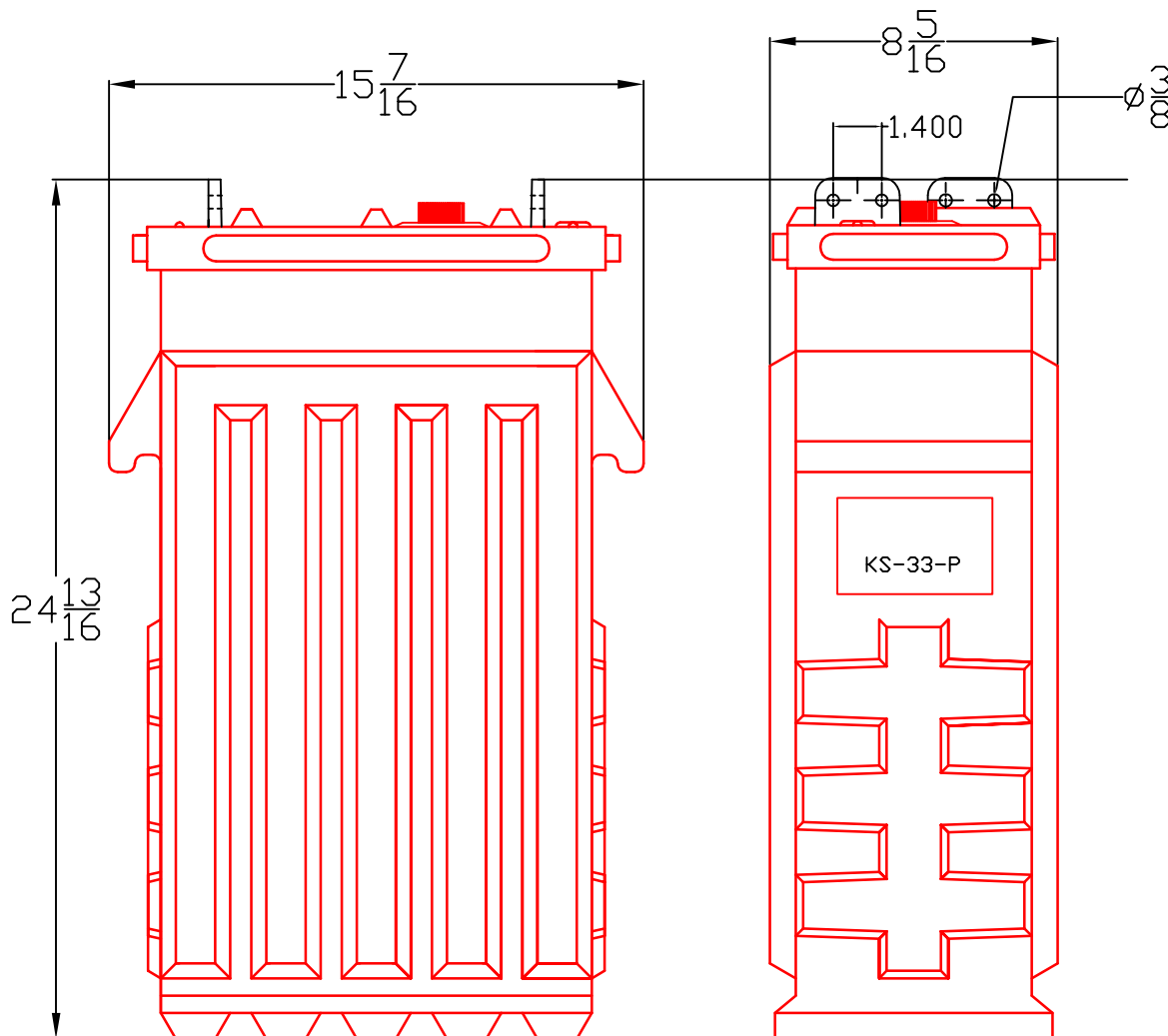

Rolls
BATTERY ENGINEERING

TITLE: 2 KS 33P

DESCRIPTION:
2V / 1 CELL 33 PLATE

CONTACT INFO:
 WEB: WWW.ROLLSBATTERY.COM
 E-MAIL: SALES@ROLLSBATTERY.COM
 PHONE: 1-800-681-9914

SCALE: 1" = 6"
8.5" X 11" JPEG:
NOT TO SCALE

DATE: JAN-2010 REVISION REV 2.0

DRAWING NO.: DWG 066, BD2KS33P