



**DEEP CYCLE**  
**SERIES: 4000**  
**MODEL: 27 HT 90**

**BATTERY ENGINEERING**  
**WWW.ROLLSBATTERY.COM MADE IN CANADA**

**BATTERY TYPE: 12 VOLTS**

**DIMENSIONS:**

<b>LENGTH</b>	324 MM	12 3/4 INCHES
<b>WIDTH</b>	168 MM	6 5/8 INCHES
<b>HEIGHT</b>	235 MM	9 1/4 INCHES

**WEIGHTS:**

<b>WEIGHT DRY</b>	21 KG	46 LBS.
<b>WEIGHT WET</b>	28 KG	62 LBS.

**CONTAINER CONSTRUCTION:**

<b>CONTAINER:</b>	POLYPROPYLENE	<b>TERMINALS:</b>	UNIVERSAL OR FLAG IF SPECIFIED
<b>COVER:</b>	POLYPROPYLENE SEALED TO CONTAINER	<b>HANDLES:</b>	PLASTIC MOUNTED TO ENDS

**PLATES:**

**POSITIVE PLATE DIMENSION:**

<b>HEIGHT</b>	127 MM	5.000 INCHES
<b>WIDTH</b>	143 MM	5.625 INCHES
<b>THICKNESS</b>	3.18 MM	0.125 INCHES

**CELLS:** 6

**PLATES/CELL:** 9

**NEGATIVE PLATE DIMENSION:**

<b>HEIGHT</b>	127 MM	5.000 INCHES
<b>WIDTH</b>	143 MM	5.625 INCHES
<b>THICKNESS</b>	2.08 MM	0.082 INCHES

**SEPARATOR THICKNESS** 1 MM 0.050 INCHES

**INSULATION GLASS MAT** 1 MM 0.020 INCHES

**CAPACITY:**

<b>CRANK AMPS:</b>		
<b>COLD (CCA)</b>	0°F / -17.8°C	405
<b>MARINE (MCA)</b>	32°F / 0°C	506

**ELECTROLYTE RESERVE:**  
**ABOVE PLATES** 38 MM 1.5 INCHES

**RESERVE CAPACITY:**  
**RC @ 25A** 99 MINUTES

**20 HR RATE: 90**

	<b>HOUR RATE</b>	<b>SPECIFIC GRAVITY</b>	<b>CAP / AH</b>	<b>CURRENT / AMPS</b>
CAPACITY @	100 HOUR RATE	1.280 SP. GR.	120	1.20
CAPACITY @	72 HOUR RATE	1.280 SP. GR.	113	1.58
CAPACITY @	50 HOUR RATE	1.280 SP. GR.	107	2.14
CAPACITY @	24 HOUR RATE	1.280 SP. GR.	93	3.9
<b>CAPACITY @</b>	<b>20 HOUR RATE</b>	<b>1.280 SP. GR.</b>	<b>90</b>	<b>4.5</b>
CAPACITY @	15 HOUR RATE	1.280 SP. GR.	85	5.6
CAPACITY @	12 HOUR RATE	1.280 SP. GR.	80	6.7
CAPACITY @	10 HOUR RATE	1.280 SP. GR.	77	7.7
CAPACITY @	8 HOUR RATE	1.280 SP. GR.	72	9.0
CAPACITY @	6 HOUR RATE	1.280 SP. GR.	67	11.1
CAPACITY @	5 HOUR RATE	1.280 SP. GR.	63	13
CAPACITY @	4 HOUR RATE	1.280 SP. GR.	59	15
CAPACITY @	3 HOUR RATE	1.280 SP. GR.	53	18
CAPACITY @	2 HOUR RATE	1.280 SP. GR.	46	23
CAPACITY @	1 HOUR RATE	1.280 SP. GR.	32	32



I STATION RD SPRINGHILL, NOVA SCOTIA CANADA B0M 1X0 1.800.681.9914

REV.2  
 Jan-10  
 27 HT 90



PART NUMBER: 27HT90  
WEIGHT WET: 62 LB / 28 KG  
WEIGHT DRY: 46 LB / 21 KG  
CAPACITY: 90 AH 20HR RATE  
VOLTAGE: 12 V  
OVERALL DIMENSIONS: 12 $\frac{3}{4}$ " X 6 $\frac{5}{8}$ " X 9 $\frac{1}{4}$ "

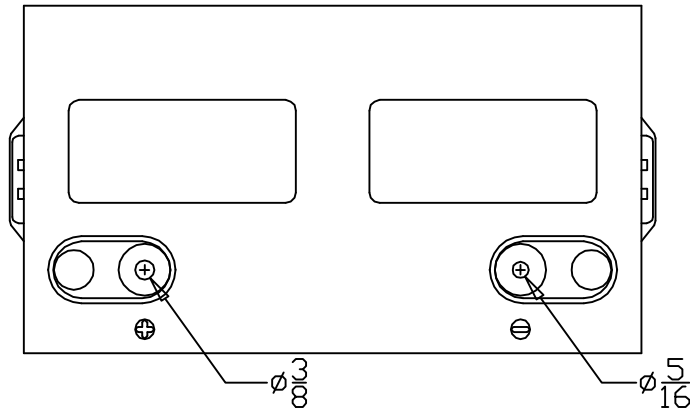

REMOVABLE HANDLE -  
SHOWN IN SIDE VIEW ONLY

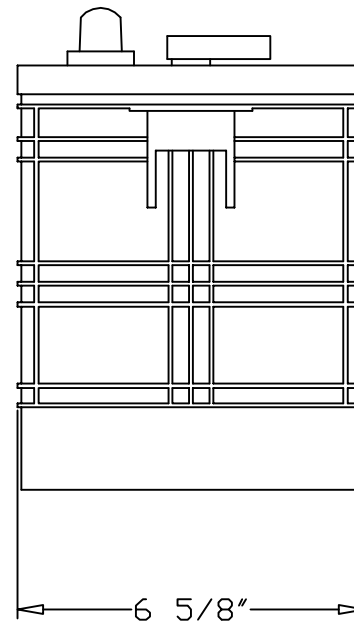
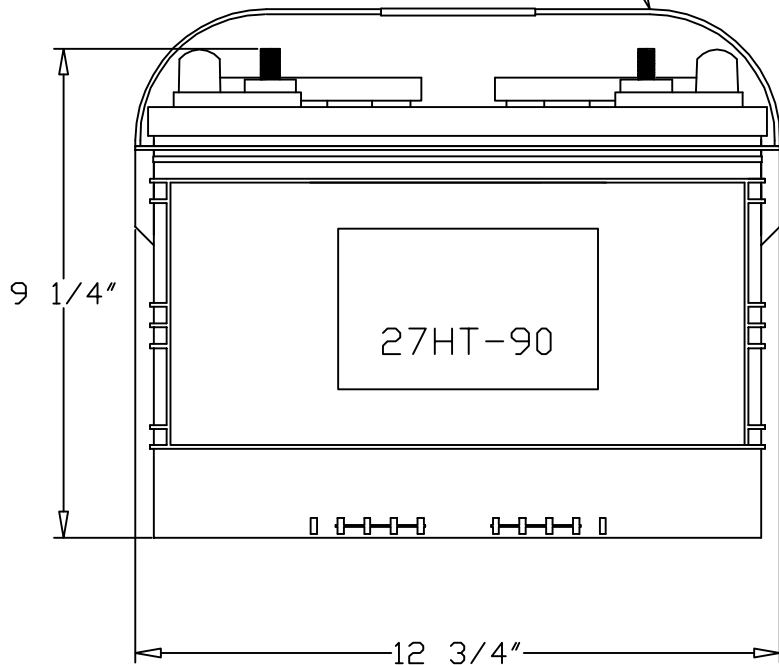

**Rolls**  
BATTERY ENGINEERING

TITLE: 27HT90

DESCRIPTION:  
12V 4000 DEEP CYCLE

CONTACT INFO:  
WEB: WWW.ROLLSBATTERY.COM  
E-MAIL: SALES@ROLLSBATTERY.COM  
PHONE: 1-800-681-9914

SCALE: 1" = 4" JPEG:  
8.5" X 11" NOT TO SCALE

DATE: JAN-2010 REVISION 2

DRAWING NO.: DWG 049, 27HT90